

# Granite Anti-Vibration Tables

Anti-vibration weighing tables for precise weighing in laboratory and industry.



SAL/STONE/C



SAL/STONE/H



SA/APP/C



SA/APP/H

## Features

### Anti-Vibration Construction

Granite top on a stainless steel construction enables convenient operation and eliminates ground vibrations that may influence measurement accuracy.

### Base Temperature

The top ensures stable temperature of the base and the highest accuracy and repeatability of measurements.

### Working Space

Large surface enables carrying out complicated measuring processes on several devices.

### Various Applications

The weighing tables are intended for operation in industry and laboratory.

## Compatible With

### SAL/STONE/C, SAL/STONE/H:

- UYA 4Y ultra-microbalances
- MYA 4Y microbalances
- XA 4Y microbalances
- XA 4Y; AS 3Y, X2, R analytical balances
- PS 3Y, X2, R; PM 4Y, C32; WLC precision balances
- WPT bridge balances

- WPW, WPY multifunctional scales
- WPW/T/H/FH, WPW/T/HR/FH waterproof control scales
- MAS, MPS, MUYA modules
- UYA 4Y SA/APP/C, SA/APP/H manual mass comparators

### SA/APP/C, SA/APP/H:

- APP.4Y.KO, PM.4Y.KB manual mass comparators

## Set Content

- Top (granite)
- Base (stainless steel or powder-coated)
- Vibration-resistant feet
- Adjustable feet

## Technical Specifications

	SAL/STONE/C	SAL/STONE/H	SA/APP/C	SA/APP/H
<b>Length</b>	1000 mm	1000 mm	700 mm	700 mm
<b>Width</b>	650 mm	650 mm	450 mm	450 mm
<b>Height</b>	815 mm	815 mm	225 mm	225 mm
<b>Top thickness</b>	115 mm	115 mm	150 mm	150 mm
<b>Load-bearing capacity</b>	150 kg	150 kg	150 kg	150 kg
<b>Granite top weight</b>	~ 190 kg	~ 190 kg	~ 155 kg	~ 155 kg
<b>Total table weight</b>	~ 215 kg	~ 215 kg	~ 180 kg	~ 180 kg
<b>Gross weight</b>	~ 225 kg + transport pallet weight (approx. 25kg)	~ 225 kg + transport pallet weight (approx. 25kg)	~ 190 kg + transport pallet weight (approx. 25kg)	~ 190 kg + transport pallet weight (approx. 25kg)
<b>Material</b>	Polished granite / powder coated steel	Polished granite / stainless steel	Polished granite / powder coated steel	Polished granite / stainless steel
<b>Packaging dimensions</b>	1000x650x800mm + transport pallet	1000x650x800mm + transport pallet	700x450x225 mm + transport pallet	700x450x225 mm + transport pallet

## Dimensions

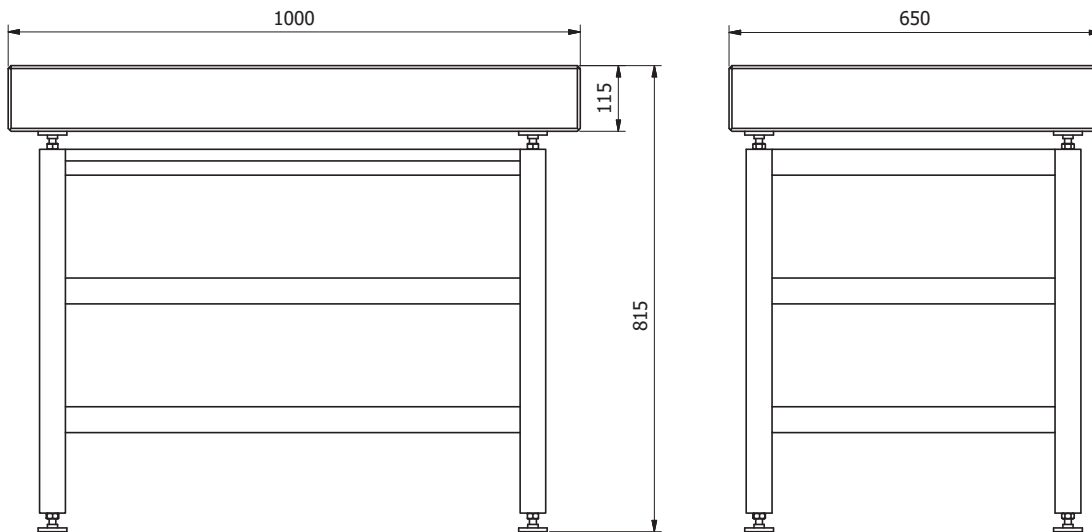

### SAL/STONE

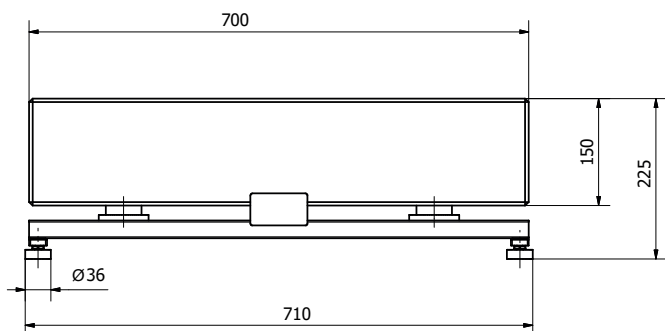

### SA/APP

